

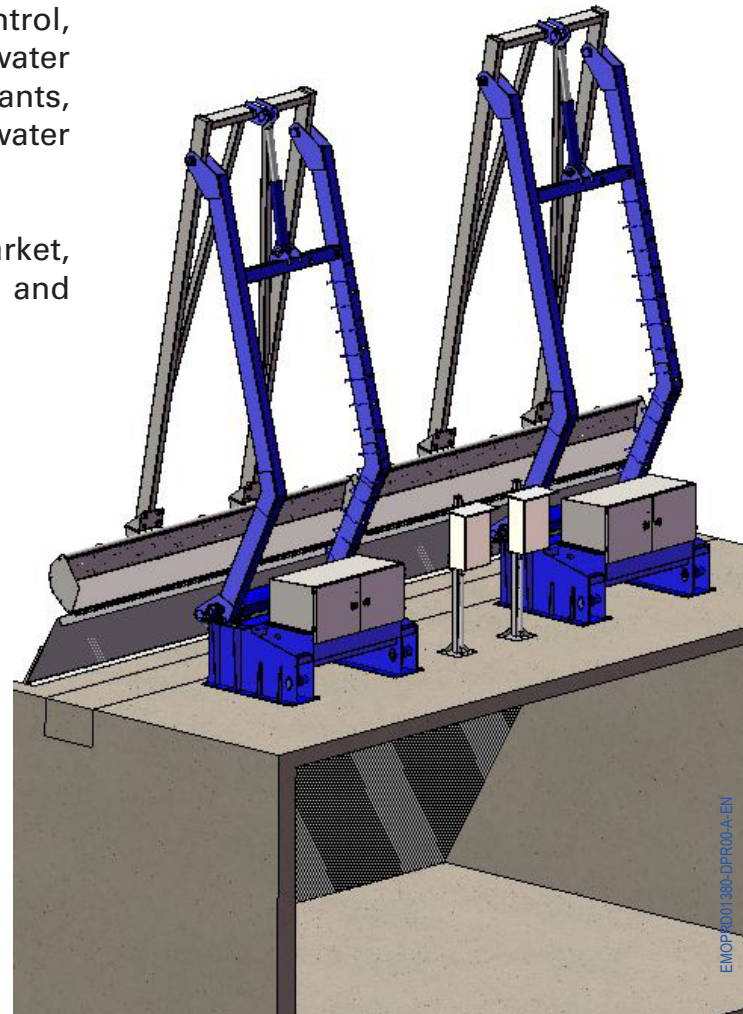

The **DATR (S-M)** range of trash rake machine is a heavy duty designed auto screen dedicated to the removal of large size debris.

This kind of machine can be used for many applications: pumping and lifting stations (irrigation, flood control, rain sewerage network), water intakes (cooling water for power plants and refineries), hydro electrical plants, municipal waste water treatment plants, drinking water plants, industrial water processing.

Among the several screens technologies on the market, key differences are the lifting capacity of the rake and the size of the debris that the machine is able to lift.



### ADVANTAGES

- No critical mechanical parts in the water
- The rake is wide opened in front of the bar rack by means of a powerful set of hydraulic cylinders in order to catch large size debris
- The lifting capacity per cycle is very high (up to 0.5 ton solids per raking)
- The rake can stop and open at any position along the downwards movement which is a big advantage in case of storm, flood ... conditions)





## OPERATING PRINCIPLE

The **DATR – S or M** is fitted with a set of 3 powerful hydraulic cylinders : two for the lifting and lowering of the rake. One for the closing of the rake.

The raking system is composed of a double forearm, a double arm and a rake.

When cycle starts, the arm opens and starts to move downwards wide open. When the bottom of the channel is reached, the arm closes down the rake on the bars. The rake closes to penetrate inside the bars and catches the debris.

While the arm keeps the rake on the bars, the forearm lifts up the debris to the top of the bars and dead plate. Once the top of the dead plate is reached, the debris fall down on a conveyor or inside a trash collector device.

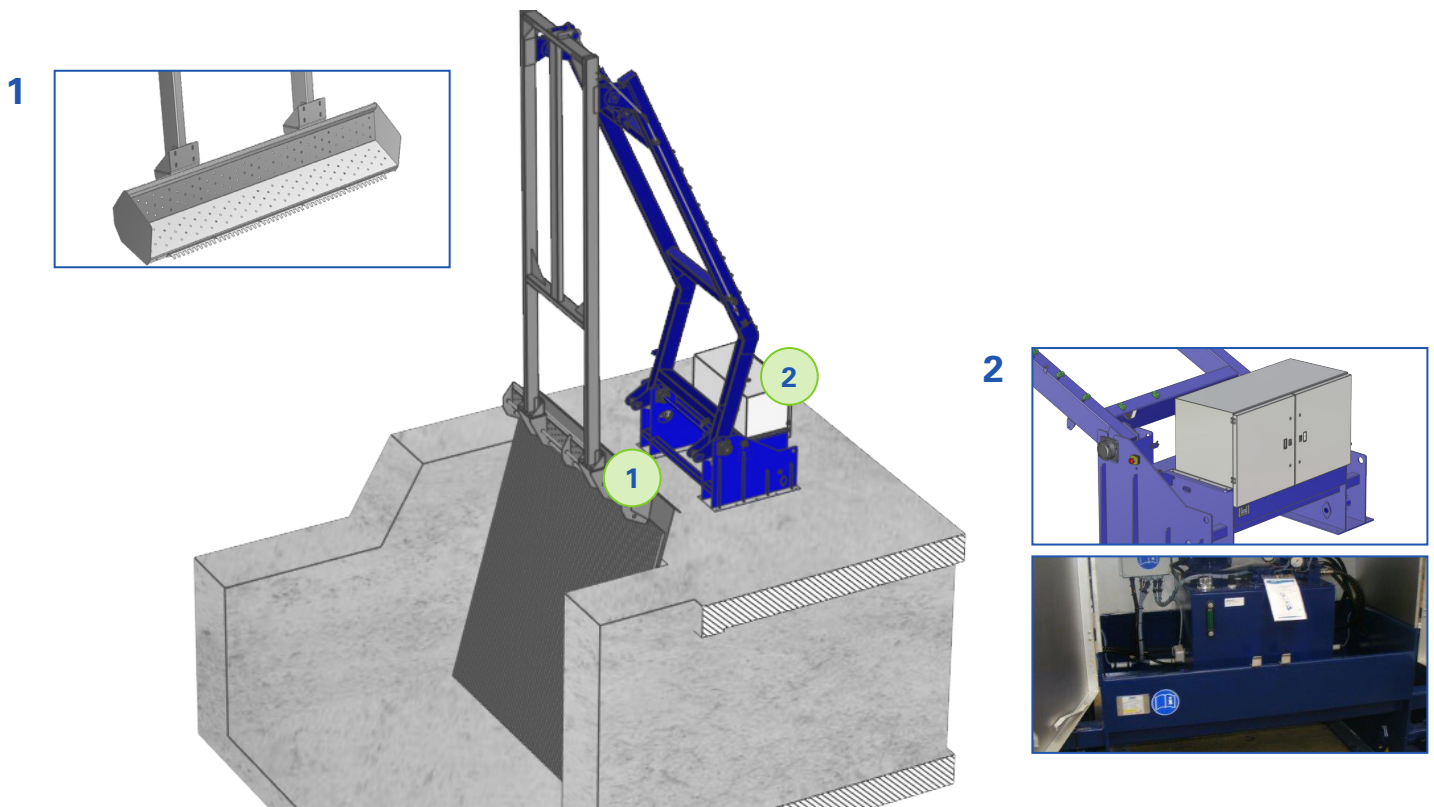

## RANGE

The **DATR-S (Static)** machine for 5 m Max width channel exists also for larger width channel (up to 50 m width). In this case, the machine is translating on rails **DATR-M (Mobile)**



**EMO sas**,  
4 rue Lépine – PA La Richardière, BP 53209, 35530 Noyal sur Vilaine, France  
+ 33 (0)2 99 86 02 03 - [emo@emo-france.com](mailto:emo@emo-france.com)

[www.emo-france.com](http://www.emo-france.com)

Certification ISO9001 - ISO14001



A company of **SEMOSIA**  
GROUP