



A range of **surface aerators** designed for wastewater treatment. Two key words are **AERATION** and **MIXING** to ensure the most efficient ratio dissolved oxygen/energy consumption.



ADVANTAGES

- Installation on a concrete footbridge or on a metallic frame
- No aeration tank shape constraints
- **STAINLESS STEEL** or **POLYESTER** aeration rotor
- Particularly suitable for aggressive environments
- Robust system = low maintenance
- Rotor open blades type to get rid of fibers and rags clogging
- Wide range of power from 1,1 to 110 kW
- Efficiency of 1,7 to 2,5 kgO²/kWh depending on model and installation conditions

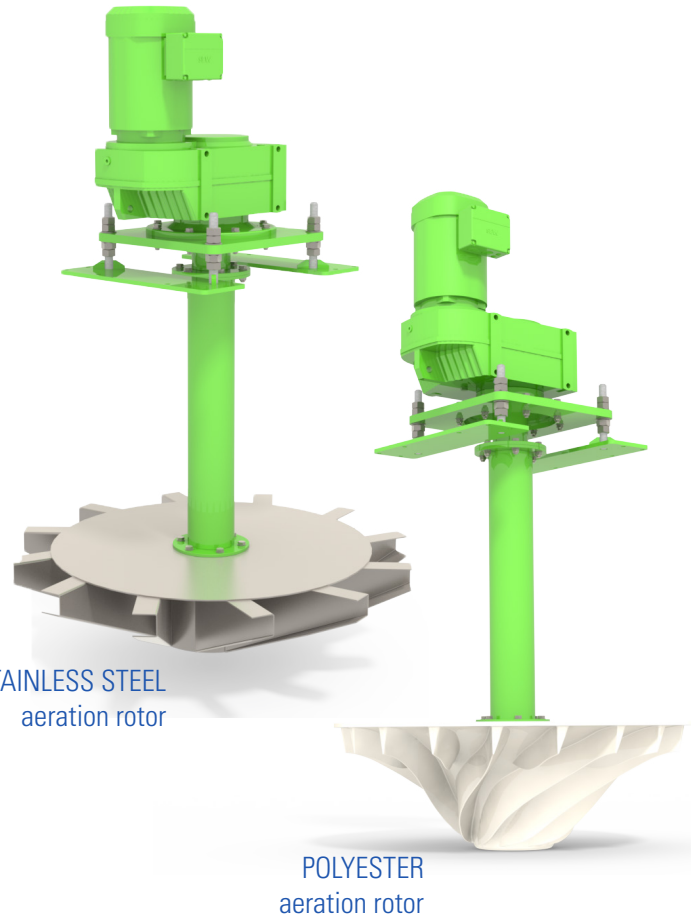

AQUIPRD0110-DPR00-A-EN





OPERATING PRINCIPLE

Wastewater aeration systems must perform two functions simultaneously:

- **dissolve oxygen** required for effluent treatment,
- **optimal mixing of the effluent** to keep solid particles in suspension and ensure good homogenisation of the environment.

The driven rotor agitates the water in the aeration tank and transfers oxygen using air-water contact by means of a spray on the surface of the aeration tank: the aerator lifts the water, creating a vacuum while the oxygen sinks back down.

The speed of rotation is determined to enable the rotor to achieve optimum mixing and oxygen yield in accordance with the customer's requirements. The **AQUAMEO LFI** has the advantage of low maintenance, there are no wearing parts that need to be replaced regularly.

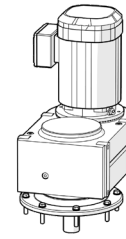

1

Drive
by a geared motor with cylindrical gear

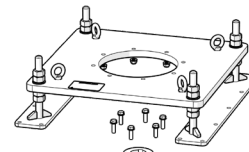

2

Anchoring and fixing
fixing plates and threaded rod anchoring

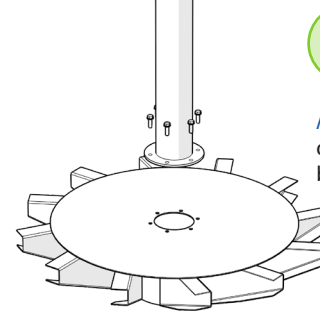

3

Aeration
disc with open blades

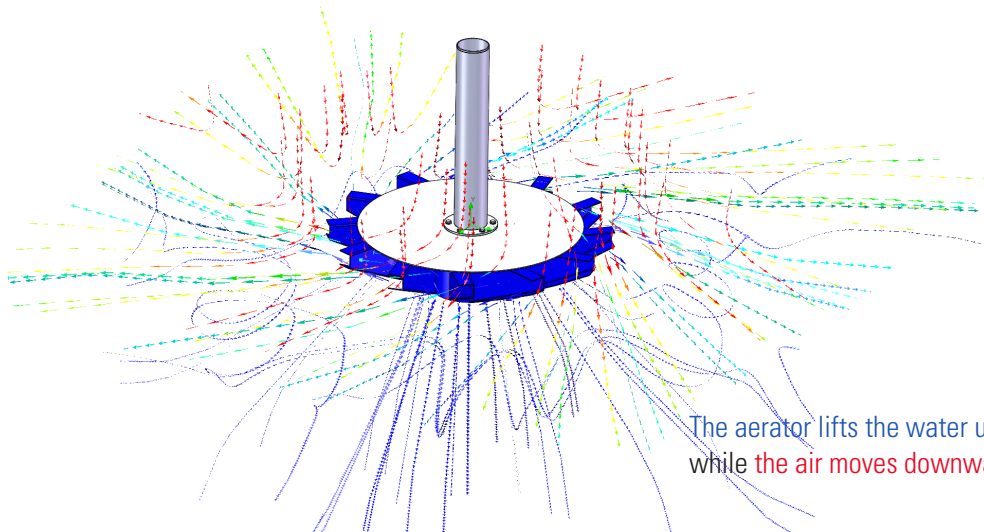

Controlled flow analysis
for a design that is ever closer to reality and optimal oxygenation.

The aerator lifts the water upwards, while the air moves downwards.



OPTIONS



Anti-projection skirt



Soundproofing enclosure



Anti-projection skirt + aluminium cover

EMO sas,

4 rue Lépine – PA La Richardière, BP 53209, 35530 Noyal sur Vilaine, France
+ 33 (0)2 99 86 02 03 - emo@emo-france.com

www.emo-france.com

Certification ISO9001 - ISO14001



A company of **SEMOSIA**
GROUP